



Pallet Stackers

D12 – D14 SP | D12 HP SP/AP

Capacity 1.2 t – 1.4 t | Series 1161

Agile double transporter

- Simultaneous pick-up of two pallets for speedy loading and unloading, efficient goods transport and order picking
- Solid steel skirt around the standing platform to protect the operator in the event of collision (SP version)
- Unique platform concept with standing position at 45° angle and Linde e-driver control for better all-round vision and an ergonomic body posture (SP version)
- Foldable vehicle platform for flexible use in pedestrian and driving mode (AP version)
- High-performance version (HP version) with greater travel and lifting speed for maximum handling performance

D12 HP AP
with side guards



D12 SP
with initial lift



D12 HP SP
with forks up



STANDARD AND OPTIONAL EQUIPMENT

Model/equipment		D12 HP SP	D12 HP AP	D12 SP	D14 SP
Safety	Automatic speed reduction when cornering	●	●	●	●
	Key switch	●	●	●	●
	Log in PIN code	○	○	○	○
	Folding sideguards and platform	–	●	–	–
	Unique, safe and intuitive 45° operating position	●	–	●	●
	BlueSpot® option - visual warning of truck presence integrated in the chassis contours	○	–	○	○
	BlueSpot® option - visual warning of truck presence mounted on accessory support	–	○	–	–
	Foot detection sensor - trucks slows down or stops if operator's foot is detected outside of the platform contours	○	–	○	○
Service	CAN bus technology	●	●	●	●
Digitalisation	Data transmission online	○	○	○	○
	Data transmission WiFi	○	○	○	○
	Linde connect:desk - local fleet management with different functional modules	○	○	○	○
	Linde connect:cloud - fleet management as a service (hosted version)	○	○	○	○
	Linde Pre-Op Check App - personalised daily check protocol for operational readiness	○	○	○	○
Operation/load handling	Speed Management - intelligent management of speed in double deck mode in relation to load on forks	○	○	○	○
	Soft landing on forks	○	○	○	○
	Lift end stop sensor	○	○	○	○
	Low speed if initial lift lowered	○	○	○	○
	Maximum operating speed limitation (8, 10, 12, 14 km/h, depending on the model)	○	○	○	○
	Load backrest h=700 mm or 1000 mm	○	○	○	○
	Overhead guard	○	–	○	○
	Dedicated work station (with storage compartments)	●	●	●	●
Environment	Coldstore -35°C (in/out) - with metal grid or standard floor mat	○	○	○	○
Workplace	Fully suspended operator compartment - both feet platform and steering unit are suspended	●	●	●	●
	Padded leg rest and backrest	●	–	●	●
	Twin-grip handlebar	●	●	●	●
	Innovative Linde e-driver control perfectly suited for the 45° operation	○	–	○	○
	Height-adjustable steering unit	○	–	○	○
	Multifunction coloured display hour meter, maintenance indication, battery discharge indicator and internal fault code indication	○	○	○	○
	Accessory support	○	○	○	○
	Support for data terminal and power supply cable 24V	○	○	○	○
	Scanner support and clipboard	○	○	○	○
	Electrical socket USB 5V	○	–	○	○
Mast	Standard	○	○	○	○
	Simplex	–	–	○	○
	Duplex	○	○	○	○
	Triplex	–	–	○	○
	Mast protection: mesh	○	○	○	○
Attachment /forks	Width over fork carriage 560 mm with fork length 1150 mm	○	○	○	○
	Width over fork carriage 680 mm with fork length 1150 mm	○	○	○	○
Axles and tyres	Drive wheel heavy duty, polyurethane non-marking	●	●	●	●
	Drive wheel high grip, polyurethane non-marking	○	○	○	○
	Drive wheel rubber	–	–	○	○
	Single load wheel, polyurethane	●	●	●	●
	Tandem load wheel, polyurethane (also available in greasable version)	○	○	○	○
	Castor wheels with spring cylinder	●	●	●	●
	Hydraulic castor wheels, electronically controlled	○	○	○	○
Double castor wheel (also available in greasable version)	–	–	●	●	
Drive and braking system	Power steering	●	●	●	●
	Maintenance-free AC motor	●	●	●	●
	Electromagnetic braking system (or electromechanic)	●	●	●	●
	Li-ION and lead-acid technology available with different battery capacities depending on the model	○	○	○	○
	Integrated charger for lead-acid and Li-ION batteries	○	○	○	○
External chargers available	○	○	○	○	
Lighting	Working lamp - with on/off switch for operation in dark environments	○	○	○	○

● Standard equipment

○ Optional equipment

– Not available

TECHNICAL DATA (according to VDI 2198)

			Linde MH	Linde MH	Linde MH	Linde MH
			D12 SP	D14 SP	D12 HP SP	D12 HP AP
Characteristics	1.1	Manufacturer	Linde MH	Linde MH	Linde MH	Linde MH
	1.2	Manufacturer's type designation	D12 SP	D14 SP	D12 HP SP	D12 HP AP
	1.2a	Series	1161-00	1161-00	1161-00	1161-00
	1.3	Power unit	Battery	Battery	Battery	Battery
	1.4	Operation	Stand on	Stand on	Stand on	Pedestrian/stand on
	1.5	Load capacity/load	Q (t)	1.2/1.0/1.0/2.0 ¹⁾	1.4/1.0/1.0/2.0 ¹⁾	1.2/1.0/1.0/2.0 ¹⁾
	1.6	Load centre distance	c (mm)	600	600	600
	1.8	Axle centre to fork face	x (mm)	874/944 ^{2) 3)}	874/944 ^{2) 3)}	874/944 ^{2) 3)}
	1.9	Wheelbase	y (mm)	1541/1611 ^{2) 3)}	1541/1611 ^{2) 3)}	1541/1611 ^{2) 3)}
Weights	2.1	Service weight	kg	-	1361 ^{4) 5)}	1351 ^{4) 5)}
	2.2	Axle load with load, front/rear	kg	-	1308/1253 (1965/1396) ^{4) 5) 6)}	1316/1235 (1973/1378) ^{4) 5) 6)}
	2.3	Axle load without load, front/rear	kg	-	321/1040 ^{4) 5)}	329/1022 ^{4) 5)}
Wheels/tyres	3.1	Tyres rubber, SE, pneumatic, polyurethane	Polyurethane	Polyurethane	Polyurethane	Polyurethane
	3.2	Tyre size, front	Ø 254 × 102	Ø 254 × 102	Ø 254 × 102	Ø 254 × 102
	3.3	Tyre size, rear	Ø 85 × 85 (2x Ø 85 × 60) ⁷⁾	Ø 85 × 85 (2x Ø 85 × 60) ⁷⁾	Ø 85 × 85 (2x Ø 85 × 60) ⁷⁾	Ø 85 × 85 (2x Ø 85 × 60) ⁷⁾
	3.4	Auxiliary wheels (dimensions)	2x Ø 140 × 50	2x Ø 140 × 50	2x Ø 125 × 60	2x Ø 125 × 60
	3.5	Wheels, number front/rear (x = driven)	1x + 1/2 (1x + 1/4) ⁷⁾	1x + 1/2 (1x + 1/4) ⁷⁾	1x + 2/2 (1x + 2/4) ⁷⁾	1x + 2/2 (1x + 2/4) ⁷⁾
	3.6	Track width, front	b10 (mm)	491 ²⁾	491 ²⁾	572 ²⁾
	3.7	Track width, rear	b11 (mm)	380/500 ²⁾	380/500 ²⁾	380/500 ²⁾
Dimensions	4.2	Height of mast, lowered	h1 (mm)	1665 ²⁾	1665 ²⁾	1915 ²⁾
	4.3	Free lift	h2 (mm)	1145 ²⁾	1145 ²⁾	1395 ²⁾
	4.4	Lift	h3 (mm)	2424 ²⁾	2424 ²⁾	4266 ²⁾
	4.5	Height of mast, extended	h4 (mm)	2944 ²⁾	2944 ²⁾	4786 ²⁾
	4.6	Initial lift	h5 (mm)	115 ⁸⁾	115 ⁸⁾	115 ⁸⁾
	4.7	Height of overhead guard (cabin)	h6 (mm)	2224 ²⁾	2224 ²⁾	2224 ²⁾
	4.9	Height of tiller arm in operating position, min/max	h14 (mm)	1207/1287 ²⁾	1207/1287 ²⁾	1207/1287 ²⁾
	4.10	Height of reach legs	h8 (mm)	80 ⁹⁾	80 ⁹⁾	80 ⁹⁾
	4.15	Height, lowered	h13 (mm)	86 ⁹⁾	86 ⁹⁾	86 ⁹⁾
	4.19	Overall length	l1 (mm)	2497 ²⁾	2497 ²⁾	2497 ²⁾
	4.20	Length to fork face	l2 (mm)	1347 ²⁾	1347 ²⁾	1347 ²⁾
	4.21	Overall width	b1/b2 (mm)	800 ²⁾	800 ²⁾	800 ²⁾
	4.22	Fork dimensions DIN ISO 2331	s/e/l (mm)	71 × 180 × 1150 ¹⁰⁾	71 × 180 × 1150 ¹⁰⁾	71 × 180 × 1150 ¹⁰⁾
	4.24	Width of fork carriage	b3 (mm)	780 ²⁾	780 ²⁾	780 ²⁾
	4.25	Fork spread	b5 (mm)	560/680 ²⁾	560/680 ²⁾	560/680 ²⁾
	4.26	Distance between wheel arms/loading surfaces	b4 (mm)	196/316 ²⁾	196/316 ²⁾	196/316 ²⁾
	4.31	Ground clearance, below mast	m1 (mm)	135/20 ³⁾	135/20 ³⁾	135/20 ³⁾
	4.32	Ground clearance, centre of wheelbase	m2 (mm)	135/20 ³⁾	135/20 ³⁾	135/20 ³⁾
	4.33	Load dimension b12 × l6	b12 × l6 (mm)	800 × 1200	800 × 1200	800 × 1200
	4.34	Aisle width predetermined load dimensions	Ast (mm)	2937/2966 ^{3) 11)}	2937/2966 ^{3) 11)}	2937/2966 ^{3) 11)}
4.34.1	Aisle width for pallets 1000 × 1200 crossways	Ast (mm)	3034/3094 ^{3) 11)}	3034/3094 ^{3) 11)}	3007/3067 ^{3) 11)}	
4.34.2	Aisle width with pallet 800 × 1200 along forks	Ast (mm)	2937/2966 ^{3) 11)}	2937/2966 ^{3) 11)}	2910/2939 ^{3) 11)}	
4.35	Turning radius	Wa (mm)	2221/2291 ³⁾	2221/2291 ³⁾	2194/2264 ³⁾	
Performance	5.1	Travel speed, with/without load	km/h	10/12 ¹²⁾	10/12 ¹²⁾	11/14 ¹²⁾
	5.2	Lifting speed, with/without load	m/s	0.19/0.32 ³⁾	0.19/0.32 ³⁾	0.15/0.27 (0.04/0.07) ^{5) 6)}
	5.3	Lowering speed, with/without load	m/s	0.37/0.19 ³⁾	0.37/0.19 ³⁾	0.35/0.34 (0.08/0.08) ^{5) 6)}
	5.8	Maximum climbing ability, with/without load	%	-	-	-
	5.9	Acceleration time, with/without load	s	6.3/4.8	6.3/4.8	-
	5.10	Service brake		hydr./electro-mech.	hydr./electro-mech.	hydr./electro-mech.
Drive	6.1	Drive motor rating S2 60 min	kW	3	3	3
	6.2	Lift motor rating at S3 15%	kW	3.2	3.2	2.6
	6.3	Battery according to DIN 43531/35/36 A,B,C,no		43 535 B/3PzS	43 535 B/3PzS	43 535 B/3PzS
	6.4	Battery voltage/rated capacity (5h)	(V)/(Ah)0. kWh	24/375	24/375	24/375
	6.5	Battery weight (±5%)	kg	327	327	327
	6.6	Power consumption according to VDI cycle	kWh/h	-	-	-
	6.6	Energy consumption according to DIN EN 16796	kWh/h	-	-	-
	6.6.1	CO ₂ equivalent according to EN 16796	kg/h	-	-	-
6.7	Turnover output according to VDI 2198	t/h	-	-	-	
6.8	Turnover efficiency according to VDI 2198	t/kWh	-	-	-	
Others	8.1	Type of drive unit		KWPC 05	KWPC 05	KWPC 05
	10.7	Sound pressure level LpAZ (at the operator's seat)	dB(A)	-	-	-

1) LP only/LP/LI/LI only
2) (±5 mm)
3) Load arms upraised/lowered
4) Figures with battery, see line

5) (±10%)
6) Figures in parenthesis with initial lift
7) Figures in parenthesis with tandem load wheels
8) (0/-5 mm)

9) (0/+5 mm)
10) Reach legs 75 × 150 × 1115

11) Including a 200 mm (min.) operating aisle clearance
12) (±5%)

D12 - D14 SP | D12 HP SP

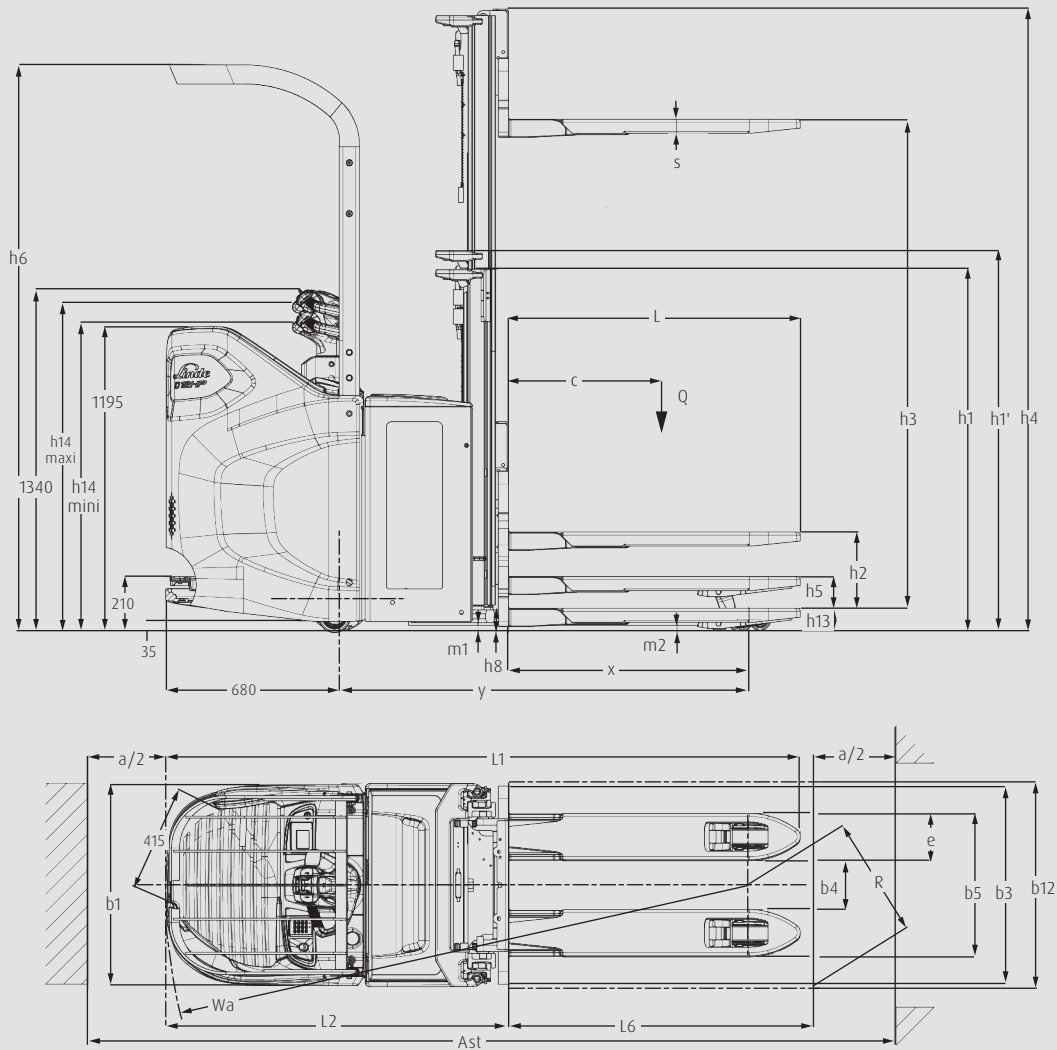

MAST TABLES

STANDARD MAST (in mm)

Series	1177											
Lift	h3: 1574		h3: 1924		h3: 2424		h3: 2924		h3: 3324		h3: 3824	
Height measurements	h1: 1240 h3: 1574 h1': 1315	h2: 150 h4: 2094	h1: 1415 h3: 1924 h1': 1490	h2: 150 h4: 2444	h1: 1665 h3: 2424 h1': 1740	h2: 150 h4: 2944	h1: 1915 h3: 2924 h1': 1990	h2: 150 h4: 3444	h1: 2115 h3: 3324 h1': 2190	h2: 150 h4: 3844	h1: 2365 h3: 3824 h1': 2440	h2: 150 h4: 4344
Model												
D12 SP	○		○		○		○		○		○	
D14 SP	○		○		○		○		○		○	
D12 HP SP	○		○		○		—		—		—	
D12 HP AP	○		○		○		—		—		—	

SIMPLEX MAST (in mm)

Series	1177			
Lift	h3: 1462		h3: 1612	
Height measurements	h1: 1915 h3: 1462 h1': -	h2: 1395 h4: 1982	h1: 2065 h3: 1612 h1': -	h2: 1545 h4: 2132
Model				
D12 SP	○		○	
D14 SP	○		○	
D12 HP SP	—		—	
D12 HP AP	—		—	

DUPLEX MAST (in mm)

Series	1177											
Lift	h3: 1574		h3: 1924		h3: 2424		h3: 2924		h3: 3324		h3: 3824	
Height measurements	h1: 1240 h3: 1574 h1': -	h2: 720 h4: 2094	h1: 1415 h3: 1924 h1': -	h2: 895 h4: 2444	h1: 1665 h3: 2424 h1': -	h2: 1145 h4: 2944	h1: 1915 h3: 2924 h1': -	h2: 1395 h4: 3444	h1: 2115 h3: 3324 h1': -	h2: 1595 h4: 3844	h1: 2365 h3: 3824 h1': -	h2: 1845 h4: 4344
Model												
D12 SP	○		○		○		○		○		○	
D14 SP	○		○		○		○		○		○	
D12 HP SP	○		○		○		—		—		—	
D12 HP AP	○		○		○		—		—		—	

TRIPLEX MAST (in mm)

Series	1177			
Lift	h3: 3516		h3: 4266	
Height measurements	h1: 1665 h3: 3516 h1': -	h2: 1145 h4: 4036	h1: 1915 h3: 4266 h1': -	h2: 1395 h4: 4786
Model				
D12 SP	○		○	
D14 SP	○		○	
D12 HP SP	—		—	
D12 HP AP	—		—	

○ Optional equipment — Not available

h1: Height of mast, lowered
h1': Height of mast, with initial lift (+75)

mm)
h2: Free lift

h3: Lift
h4: Height of mast, extended

D12 HP AP

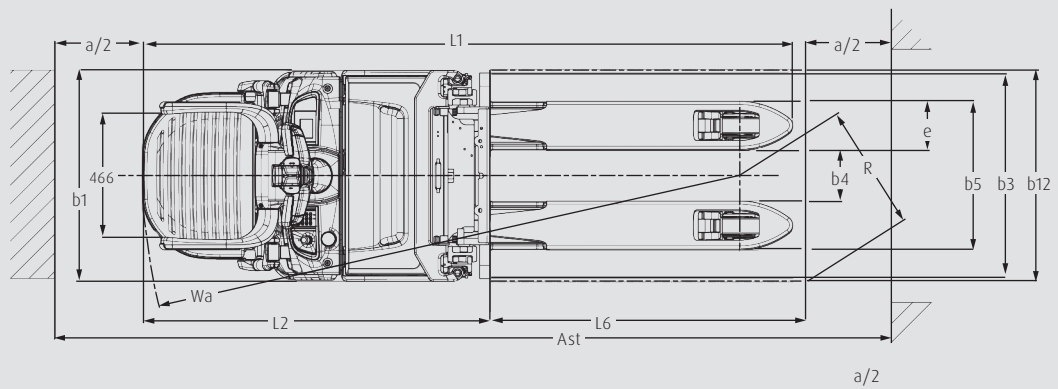
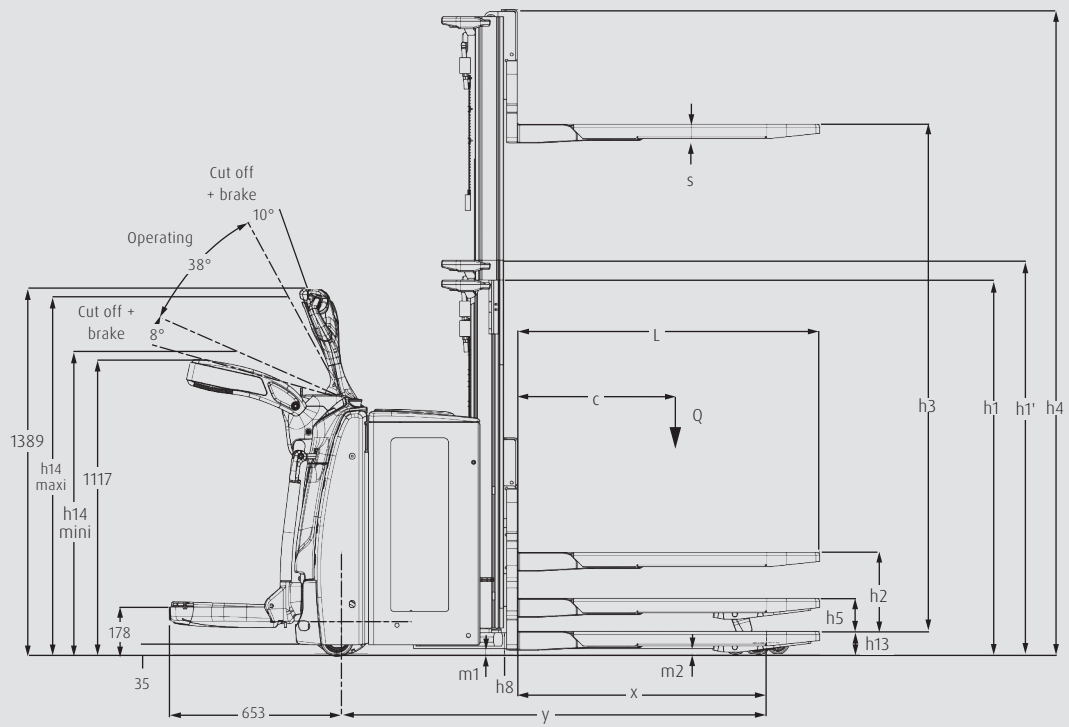

CHARACTERISTICS



Safety enhanced with speed reduction when cornering

Safety

- Automatic adjustment of operating speed when cornering to prevent risky manoeuvres
- Wide mast design for optimal visibility of the load and the immediate vehicle environment
- Operator always remains within the contours of the vehicle for optimum protection in any situation
- Solid steel skirt as a protective shield to protect the operator from injury in the event of a collision (SP version)
- Foot detection automatically brings the vehicle to a smooth stop when operator's



Ergonomic, height-adjustable tiller

Ergonomics

- Linde OptiLift assistance system for precise control of mast functions at high working speeds and quiet, energy-saving load handling
- Fully decoupled operator platform to protect the operator from vibrations and shocks
- Innovative steering concept Linde e-driver for optimum, single-handed control of the vehicle in the 45° position if required (SP version)
- Electric power steering for effortless vehicle control in any work situation
- Automatic and gradual adjustment of the travel speed to the steering angle for precise manoeuvring in tight spaces



Perfect combination between power and manoeuvrability

Handling

- High residual capacities for maximum vehicle stability when working at height
- Powerful 3 kW three-phase motor for rapid acceleration even with double load
- High top speeds (14 km/h without load, 11 km/h with load, 7.5 km/h with double load) for fast transport travel (HP version)
- Five-point configuration with optional electrically controlled and hydraulically operated castor wheels for perfect vehicle stability (HP version)
- Optional shortened truck version with Li-Ion battery allows for smaller turning radius, especially in tight spaces (HP version)



Easy access to components and data

Service

- Robust 3 kW three-phase motor for long service intervals and low maintenance costs
- Solid construction with durable parts and sturdy chassis for maximum vehicle availability
- Design-to-service principle for effortless accessibility to all relevant components
- Innovative CAN bus structure for fast error analysis via diagnostic connector
- Modern E/E architecture allows remote installation of updates and new functions

Subject to modification in the interest of progress. Illustrations and technical details could include options and are not binding for actual constructions. All dimensions subject to usual tolerances.



ncnielsen

Nørregade 66, DK-7860 Balling | Tlf.: +45 99 83 83 83
nc-nielsen.dk | info@nc-nielsen.dk